

RESULTS OF DEVELOPMENT AND RESEARCH OF THE TECHNOLOGY FOR AUTOMATED ENERGY-EFFICIENT CONTROL OF HEAT PUMP SYSTEMS BY MEANS OF COMPUTER EXPERIMENT

The development of energy-efficient indoor management systems, involving the current engineering and technical solutions to control and optimize energy consumption, is both relevant and promising area. This allows addressing the issues of saving energy resources; improving energy efficiency; and strengthening energy independence. The use of geothermal heat pumps and air conditioning systems with heat utilization are the advanced areas for the development of energy-efficient technologies in the construction sector. The paper concerns the study of technical-functional and energy characteristics, and parameters of a residential building heat supply system with integrated automated control means by synthesizing computer-oriented and computer-integrated models of heating and air conditioning systems using a geothermal heat pump and a thermal accumulator which will increase the energy efficiency of the building and optimize the use of thermal energy throughout the year. The object of study is the processes of accumulation, distribution and utilization of thermal energy in heating and air conditioning systems. The subject of the study is computer-aided models of indoor heat supply including a geothermal heat pump, a thermal accumulator and a radiator heating system as well as an air conditioning system with the possibility of heat utilization. The main scientific and practical effect of the obtained results is the development of computer-oriented models of indoor heating and air conditioning systems which, unlike the previously known ones, implement adaptive heat utilization to the heat accumulator for hot water supply needs. Further promising research in the areas will expand and deepen the scientific substantiation of software and hardware solutions aimed at improving the energy efficiency of heat engineering industrial and household facilities and processes.

Keywords: thermal accumulator, computer-aided model, heat utilization, heat pump, air conditioning.

ОЛІШЕВСЬКИЙ ІЛЛІА

Національний технічний університет «Дніпровська політехніка»

РЕЗУЛЬТАТИ РОЗРОБКИ ТА ДОСЛІДЖЕННЯ ТЕХНОЛОГІЇ АВТОМАТИЗОВАНОГО ЕНЕРГОЕФЕКТИВНОГО КЕРУВАННЯ ТЕПЛОНАСОСНИМИ СИСТЕМАМИ МЕТОДАМИ КОМП'ЮТЕРНОГО ЕКСПЕРИМЕНТУ

Розробка енергоефективних систем управління будівлями, що використовують сучасні інженерно-технічні рішення для контролю та оптимізації енергоспоживання, є актуальним і перспективним напрямком. Це дозволяє вирішувати питання економії енергоресурсів, підвищення енергоефективності та посилення енергонезалежності. Використання геотермальних теплових насосів та систем кондиціонування з утилізацією тепла є перспективними напрямками розвитку енергоефективних технологій у будівельному секторі. Ця стаття присвячена дослідженню техніко-функціональних і енергетичних характеристик та параметрів системи тепlopостачання житлового будинку з інтегрованими засобами автоматизованого керування за рахунок синтезу комп'ютерно-орієнтованих і комп'ютерно-інтегрованих моделей систем опалення та кондиціонування будівлі з використанням геотермального теплового насоса і теплового акумулятора, що дозволить підвищити енергоефективність будівлі та оптимізувати використання теплової енергії протягом року. Об'єктом дослідження є процеси накопичення, розподілу та утилізації теплової енергії у системах опалення та кондиціонування. Предметом дослідження є комп'ютерно-орієнтовані моделі теплотехнічного забезпечення будівлі, що включають геотермальний тепловий насос, тепловий акумулятор та систему радіаторного опалення, а також систему кондиціонування повітря з можливістю утилізації тепла. Основний науково-практичний ефект від отриманих результатів полягає в розробці комп'ютерно-орієнтованих моделей систем опалення та кондиціонування будівлі, які, на відміну від раніше відомих, реалізують адаптивну утилізацію тепла до теплового акумулятора для потреб гарячого водопостачання. Проведення подальших перспективних досліджень у зазначених напрямках дозволить розширити та поглибити наукове обґрунтування програмно-технічних рішень, спрямованих на підвищення енергоефективності теплотехнічних промислових і побутових об'єктів та процесів.

Ключові слова: тепловий акумулятор, комп'ютерно-орієнтована модель, утилізація тепла, тепловий насос, кондиціонування.

1. Introduction

The world needs an increase in energy efficiency of buildings to decrease consumption of power resources as well as greenhouse gas reduction [1–4]. Rising energy prices and focusing on environmental aspects require implementation of innovative approaches to energy consumption management [5]. It should be mentioned that during the last four decades, the centralized heat supply systems were maintained in Ukraine just in their available condition; average deterioration level of them is more than 68% [6]. Considerations of constant dynamics as for thermal energy losses in the Ukrainian heat networks (Fig. 1) [7] put into the forefront the problems connected with the development, modernization, and improvement of measures intended to stimulate end users for application of renewable energy sources, and expansion of the possibilities of alternative energy supply schemes [8]. In this context, systems of heat pumps and thermal accumulators (TA) are among the most promising decisions as for efficient heating of buildings [9, 10].

Hence, the constant dynamics of losses arising during heat supply through the centralized system as well as increase in energy prices stipulates the necessity to develop and implement non-traditional heat supply methods. The fact should also be mentioned that heating during cold seasons and hot water supply throughout the year determine the increased need for computer-integrated intelligent energy-efficient control of heat pump systems. In such a way, it becomes necessary to develop models of automated computer-integrated control for the components of heat

networks which will help increase the coefficient of energy transformation, and energy efficiency of heat supply process.

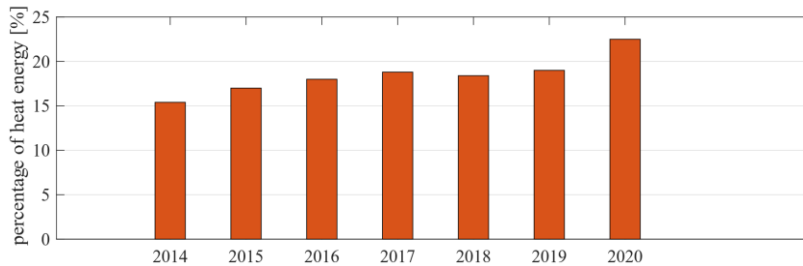

Fig. 1. Dynamics of heat energy losses in the heating networks of Ukraine [8]

Taking into consideration the abovementioned, one can state that the paper topic is relevant, and importance of the expected scientific and applied effect is to develop such computer-oriented models of indoor heating and cooling systems which, unlike early known ones, implement adaptive heat utilization to a thermal accumulator for hot water supply.

The key purpose of the paper is to analyze both technical and functional, and energy characteristics as well as parameters of heat supply system for residential building with the integrated means of the automated control at the expense of synthesis of computer-oriented models of the building heating and cooling through the use of geothermal heat pump, and thermal accumulator. The abovementioned will help improve energy efficiency of the building and optimize the heat energy use for a full year. The research object includes processes of thermal energy accumulation, distribution, and utilization within the heating and cooling systems. The research subject involves computer-oriented models for a building heating consisting of a geothermal heat pump, thermal accumulator, radiator heating system, and air conditioning system with the possibility of heat utilization.

2. Limitations and characteristics of the simulation process

The paper research is logical continuation of proper theoretical studies in the field of development of procedures to calculate parameters for non-traditional technologies for heating and conditioning of buildings represented in scientific papers [11–13]. The obtained results have been validated through testing of computer models in the MATLAB Simscape simulation environment [14].

One-story building with 450-m³ internal volume and 15x12x2.5-m overall dimensions was selected as the basis for the simulation (Fig. 2). Table 1 shows explication of the premises. Light concrete is a load-bearing material of protective structures. Mineral wool is a heat insulation material. Decorative and finishing materials are ignored. Statistical data of ambient air temperature have been selected for climatic conditions of Dnipropetrovsk Region.

Table 1

Explication of the premises

#	Premises	Name in the model	Area, square meters
1	Bedroom 1	Bedroom 1	19.8
2	Bedroom 2	Bedroom 2	20.5
3	Kitchen-living room	Kitchen-living room	71.7
4	Bathroom	-	5.3
5	Corridor	-	10.8
6	Bedroom 3	Bedroom 3	25.1
7	Bedroom 4	Bedroom 4	15.4
	Living area of the house	-	152.5
	The total area of the house	-	180

Two-phase liquid refrigerant R410a has been applied as a vapour compression machine. Table 2 demonstrates output data for the development of a conditioning system model.

Table 2

Output data

Parameter	Value
Ambient air temperature	30-36°C
Desirable indoor temperature	22°C
The house area	180 m ²
Refrigerating capacity	20 kW or 5.6 tons of the cooled mass

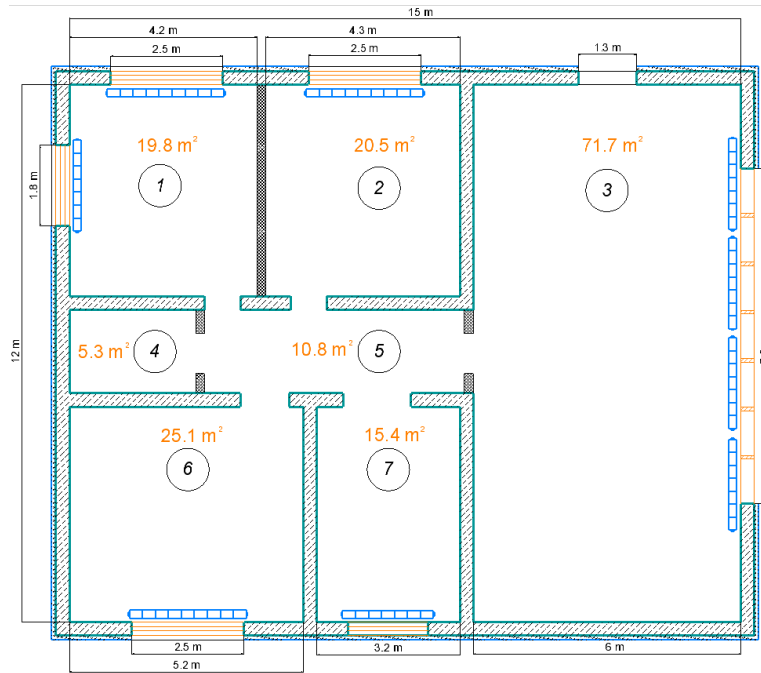

Fig. 2. The house plan

To identify the parameters of the condenser, vaporizer, expansion valve, and receiver, four points of the desirable refrigeration cycle have been identified within *P-i* diagram of the refrigerant (Fig. 3) summarized in the Table 3.

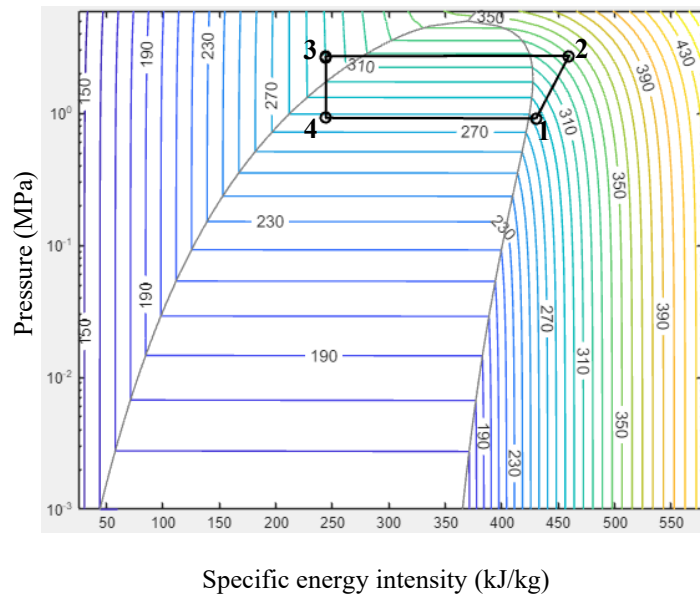

Fig. 3 *P-i* diagram of R410a

Table 3

Refrigeration cycle				
	Point number	Pressure, MPa	Specific energy intensity, kJ/kg	Note
Evaporator, output	1	0.795	429.17	5°C is temperature of the refrigerant evaporation
Condenser, input	2	2.72	457	65°C is nominal input temperature
Condenser, output	3	2.72	245.26	5°C is the condenser supercooling
Evaporator, input	4	0.795	245.26	-

Refrigerant condensation temperature within the conditioning system is 45°C (according to the refrigerant parameters) which makes it possible to ensure 9-15°C difference with ambient air temperature. In the context of the simulation, 30°C-36°C environmental mode during eight hours has been assumed. Evaporation temperature of the refrigerant in the evaporator is 5°C to remove heat from the building at the desirable 22°C temperature.

Within the heating model, the specified average temperature is 21°C. At the same time, ambient air temperature varies from -3 °C up to 9 °C and ground temperature varies from 6°C to 10°C.

3. Results of the computer model development for heating and hot water supply

Fig. 4 shows a computer model of a system intended to develop such an indoor temperature mode corresponding to sanitary requirements, and hot water supply demands where 1 is controller to generate enquiry message for relevant actuators within the system maintaining the specified indoor temperature; 2 is configuration block of the *two-phase fluid* refrigerant; 3 is subsystem of geothermal heat pump; 4 is block to set ambient temperature variation; 5 is subsystem with a thermal model of indoor premises *house subsystem*, and hot water supply radiators for heat distribution and thermal accumulator; 6 is *underground environment* subsystem describing a run of pipes joined in a circuit digged horizontally at a shallow depth near the residential building; and 7 is block to specify ground temperature *Underground temperature variation*.

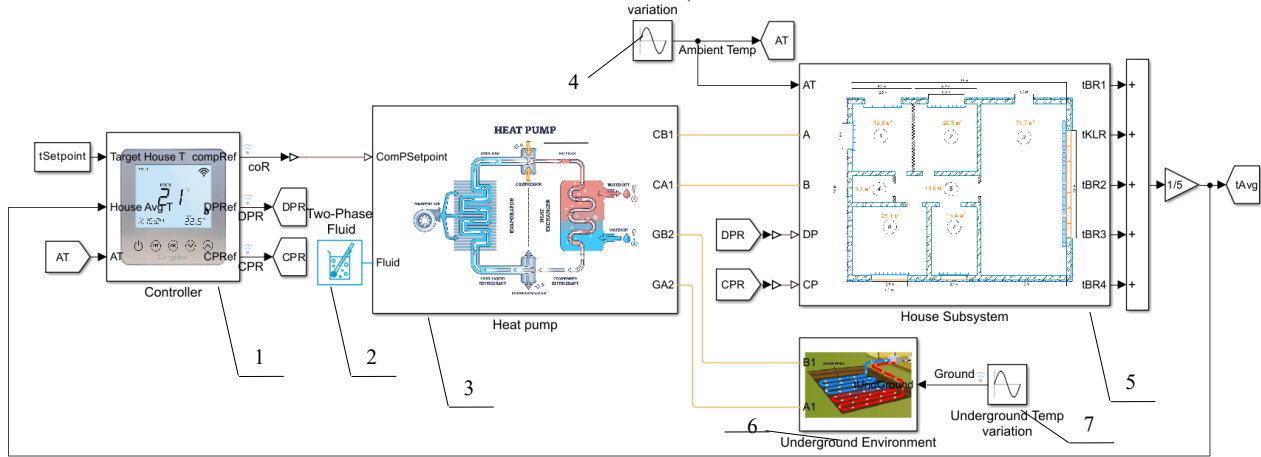

Fig. 4. Computer model of heating and hot water supply system on the basis of a geothermal heat pump

The geothermal heat pump (Fig. 4, mark 3) applies two-phase liquid refrigerant R410a as a working liquid (selected as analogue to freon – 11). The thermal pump takes natural heat from the ground (Fig. 4, mark 6) and transfers it to the hot water supply radiators (Fig. 4, mark 5). A controller (Fig. 4, mark 1) generates control actions on a compressor within the heat pump subsystem (Fig. 4, mark 3) as well as on pipes in the subsystem of thermal model of the building (Fig. 4, mark 5) to maintain the specified temperature.

Fig. 5 demonstrates a *house subsystem* being a thermal model of residential building with hot water supply radiators where 1 is circulating pump running water flow through a thermal pump condenser (Fig. 4, mark 3); 2 is thermal accumulator to store hot water coming out of the condenser; 3 is dispenser pump supplying hot water flow from the thermal accumulator to radiators; 4 is configuration block of liquid property as for connected network of thermal liquids; 5 is block of radiator subsystem (the parameters are individual for each room); and 6 is block of thermal model of the premises (the parameters are individual for each room). Such thermophysical characteristics of a building as pattern of a protective structure; thermal conductivity; thickness of the protective structure layers; glass area and type; household heat release level etc. are specified within the residential building subsystem (Fig. 5).

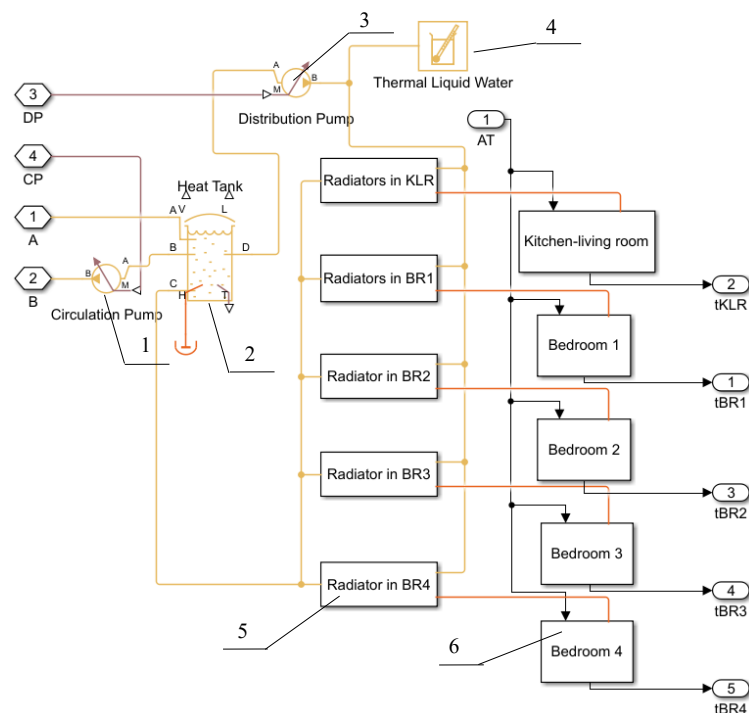

Fig. 5. House Subsystem

Graphs in Fig. 6 explain temperature variations in each room in comparison with the ambient air and ground temperature fluctuations. The initial indoor temperature is 12°C, and heat pump increases the average temperature up to specified 21°C. The initial ground temperature is 8°C; and the initial ambient air temperature is -3 °C. A simulation interval is 48 hours.

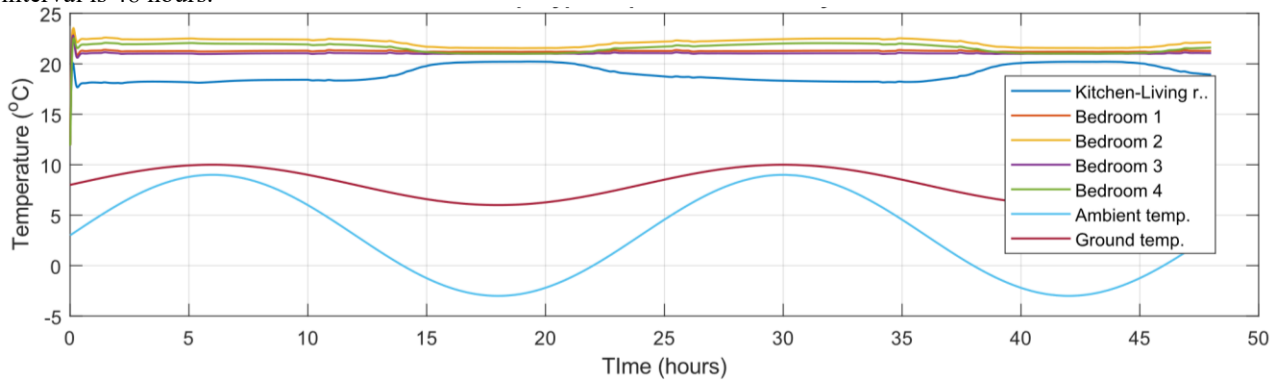

Fig. 6. Ground, ambient air, and indoor temperatures

Figures 7-8 show graphs of energy consumption and heat load of different components of a thermal pump. Fig. 7 explains the capacity, consumed by a compressor, and thermal load of a heat pump components. Fig. 8 demonstrates a coefficient of performance (COP) being a ratio between thermal capacity of a condenser and capacity consumed by a compressor. Graphs in Figures 7-8 make it understandable that more energy is consumed if thermal load is higher, i.e. when ambient air temperature drops. In turn, less energy is consumed if thermal load is less, i.e. when ambient air temperature increases.

A Graph in Fig. 8 shows that thermal energy provision by the equipment is at least three times more than its power consumption.

Fig. 9 is a graph of average indoor, ambient air, and ground temperatures. The graph explains that heat pump increases promptly average indoor temperature up the specified 21°C, and maintains it during the whole simulation period despite disturbances in a control system in the form of ambient air and ground temperature variations. Fig. 10 demonstrates mass consumption of refrigerant (compRef) and hot water to circulation (CPreF) and dispenser (DPreF) pumps under the mentioned disturbance in the system.

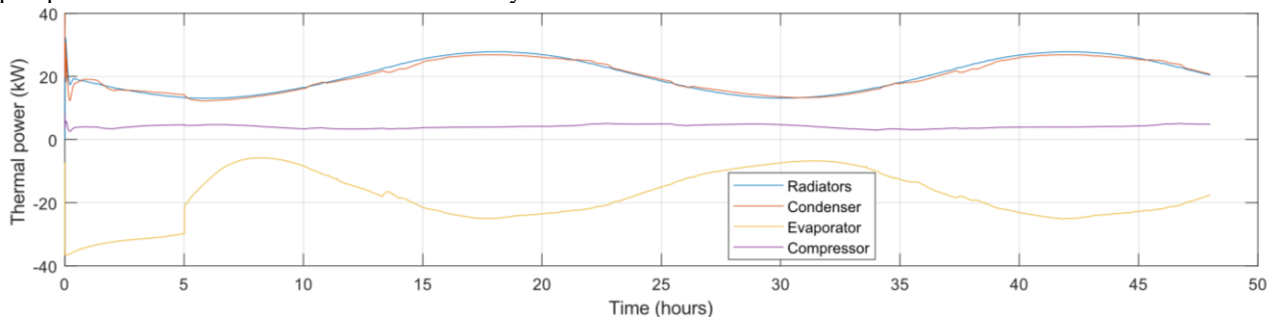

Fig. 7. Heat release and capacity of the compressor

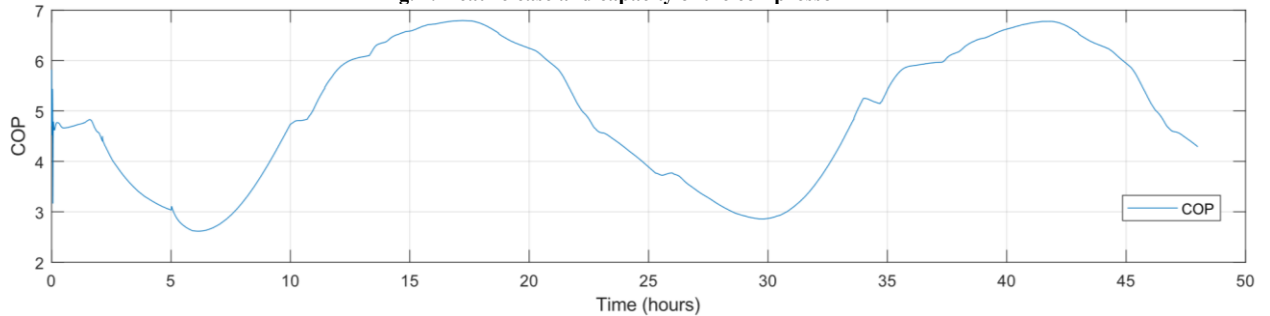

Fig. 8. Coefficient of performance

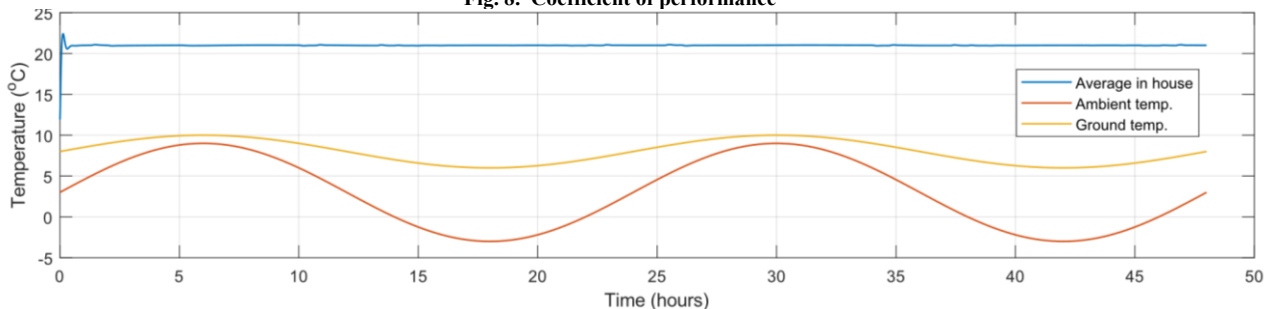

Fig. 9. Average indoor temperature

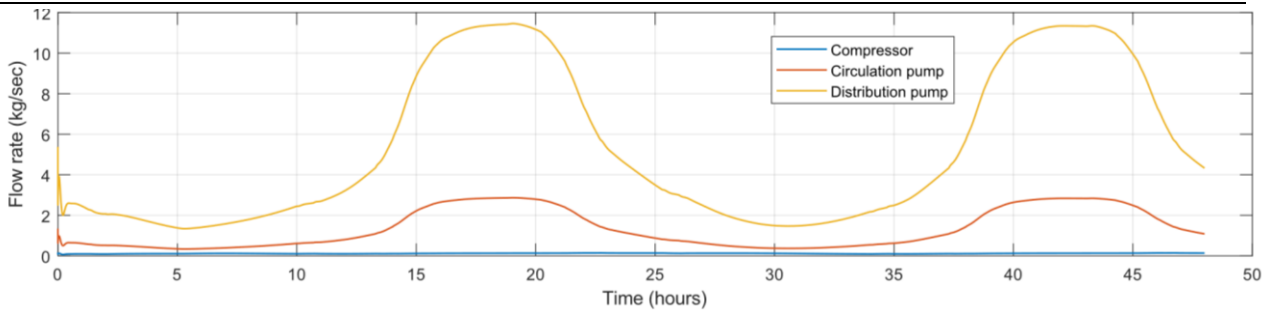

Fig.10. Output control signals of the Controller system

4. Results of the development and analysis of a computer model of conditioning system with thermal accumulator for hot water supply

Fig. 11 demonstrates a computer model of a conditioning system with the possibility to accumulate thermal energy from a condenser of external block of the cooling system where 1 is external block of the conditioning system, AC outdoor subsystem; 2 is internal block of the conditioning system, AC indoor subsystem; 3 is thermal model of a building, house subsystem; 4 is block to set ambient air temperature, Ambient temp; 5 is averaged value of indoor temperature where air is cooled during warm season, T_house; 6 are thermostats to maintain the specified indoor temperature, Thermostat_AC, and hot water temperature in the thermal accumulator, Thermostat_HT; and 7 is MATLAB Function block with control logic of heat removal from the external block 1 condenser.

Fig. 12 shows AC indoor subsystem simulating operation of the internal block of conditioning system where 1 is expansion valve; 2 is evaporator; 3 is block to set air mass volume to be cooled; and 4 is a blower subsystem describing the fan drive. The blower subsystem is a ventilator within the network with wet air and angular velocity source generating at its terminals such a speed difference which is proportional to the physical input signal.

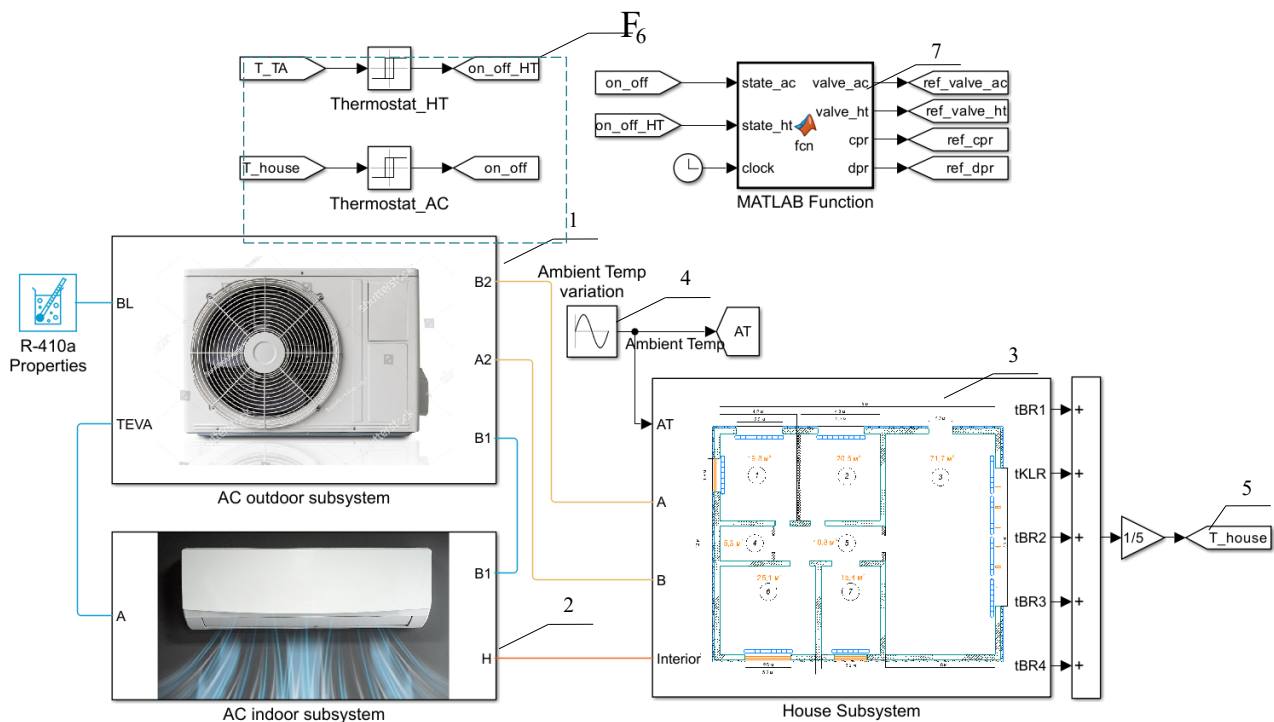

Fig. 11. Computer model of a conditioning system with a thermal accumulator

Indoor interaction (Fig. 11, mark 3) between the evaporator (Fig. 12, mark 2) and air mass (Fig. 12, mark 3) is represented using a *system-level condenser evaporator (2P-MA)* block [15]. The block can operate either as a condenser (Fig. 12, mark 2) or as an evaporator in the refrigerating system depending upon the heat-transfer direction. The block uses data on the efficiency from technical specification of the heat exchanger. Before implementation of the closed circuit of the vapour compression device, operating by the main refrigeration cycle, mass consumption of the coolant has been assessed as well as approximate air consumption values taking into consideration following information from Tables 2, and 3:

- the coolant consumption was evaluated previously as the cold productivity division by a difference between the specific enthalpy at the output of the evaporator, and the specific enthalpy at the input of the evaporator being 20 kW (i.e. $429.17 \text{ kJ/kg} - 245.26 \text{ kJ/kg} = 0.11 \text{ kg/sec}$; and

• the air consumption was evaluated previously as the cold productivity division by air pressure coefficient. The obtained result was divided by the desired air difference on the evaporator. Within the system under simulation, 10°C level is assumed being equivalent to temperature drop by 10 K. Hence, $20 \text{ kW}/1 \text{ kg/kJ/K}/10 \text{ K} = 2.0 \text{ kg/sec}$. To calculate volume velocity of the flow, the mass air flow velocity has been divided by the air density, i.e. $2.0 \text{ kg/sec}/1.2 \text{ kg/m}^3 = 1.66 \text{ m}^3/\text{sec}$.

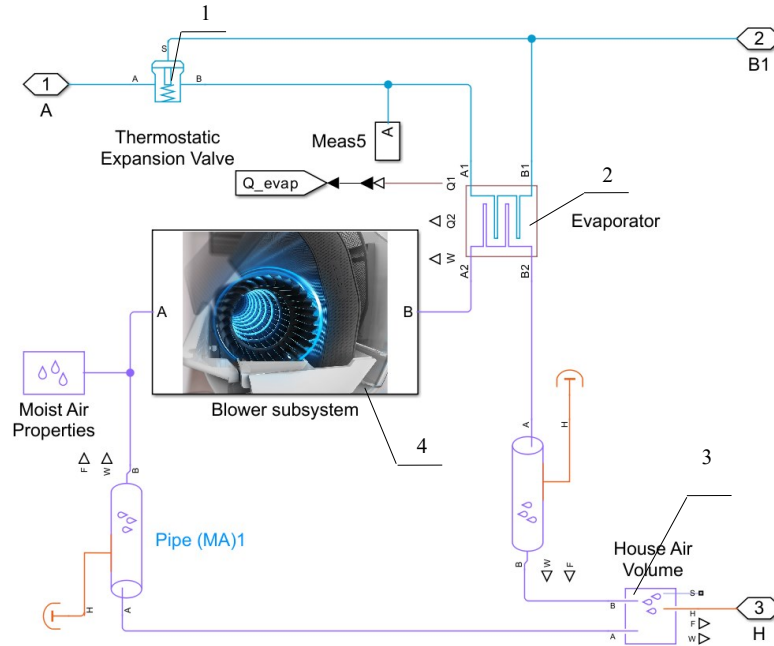

Fig. 12. AC indoor subsystem

The established value of the opening fraction of the thermostatic expansion valve (Fig. 12, mark 1) for the model is almost 0.8. While simulating, the thermostatic expansion valve (EPB) has been applied to control evaporator activity. The block modulates a flow to the evaporator based upon the measured thermal overload. 1–A input and 2–B1 output of AC indoor subsystem are connected with the rest of the refrigeration circuit of the closed system through 4–TEVA and 5–B1 terminals of AC outdoor subsystem (Fig. 13).

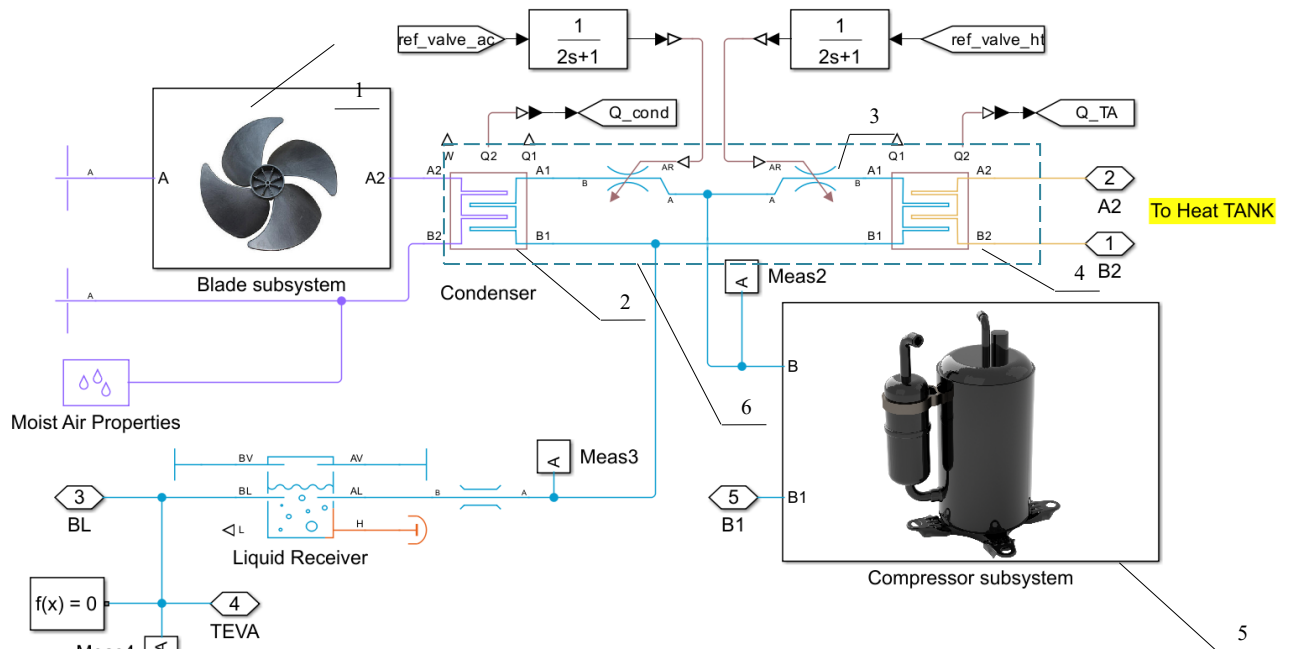

Fig. 13. AC outdoor subsystem

Consequently, the operation algorithm of the developed refrigeration cycle model is described as follows. The evaporator (Fig. 12, mark 2) absorbs indoor air heat, and transforms refrigerant into superheated vapour. Then the compressor (Fig. 4.13, mark 5) produces pressure and passes the refrigerant through a condenser (Fig. 13, mark 6) where the heat, absorbed by refrigerant, and work of compression are released into the environment (Fig. 13, mark 2)

or pass to a thermal accumulator (Fig. 13, mark 4) for a hot water supply system. As a result, the refrigerant is condensed into supercooled liquid to be stored in a liquid receiver. A valve (Fig. 12, mark 1) controls the amount of the refrigerant flowing from a receiver to evaporator to maintain the required overheating level. Also, the valve causes a pressure drop. The abovementioned cools the refrigerant rendering it possible to absorb heat in the evaporator. A building (Fig. 2), represented as air volume in a wet zone (Fig. 12, mark 3), is cooling load in the model. Heat network (Fig. 11, mark 3) simulates thermal exchange between the hot environment and indoor air through walls, roof, and windows. The developed computer model ignores indoor heat generation by residents and devices. A fan (Fig. 12, mark 4) circulates air to be cooled through the evaporator. The system is controlled by a thermostat, turning the system in/out, to maintain the specified air temperature at the level of 22°C, and water temperature in the thermal accumulator at the level of 38°C.

Below, you can find simulation results of the described computer model of conditioning with thermal accumulator for hot water supply. Figures 14-16 demonstrate operation schedules of the conditioning system without activation of TA loops.

Fig. 14 shows a graph of changes in the ambient air temperature; a setting value for the desired indoor temperature; and a graph of the averaged indoor temperature value. Graphs in Fig. 15 demonstrate heat exchange within the condenser and evaporator as well as capacity consumed by a compressor. Fig. 15 is a graph of performance coefficient calculated as ratio between the evaporator heat transfer and the total consumed capacity (consumption by the compressor and ventilators).

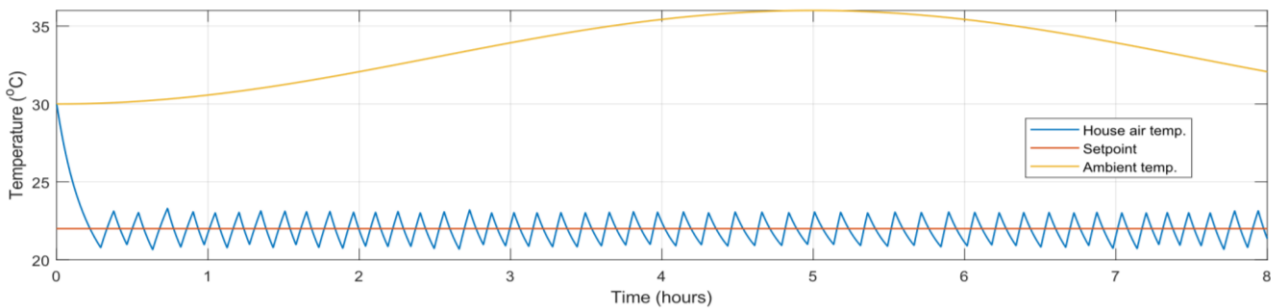

Fig. 14. Indoor temperature

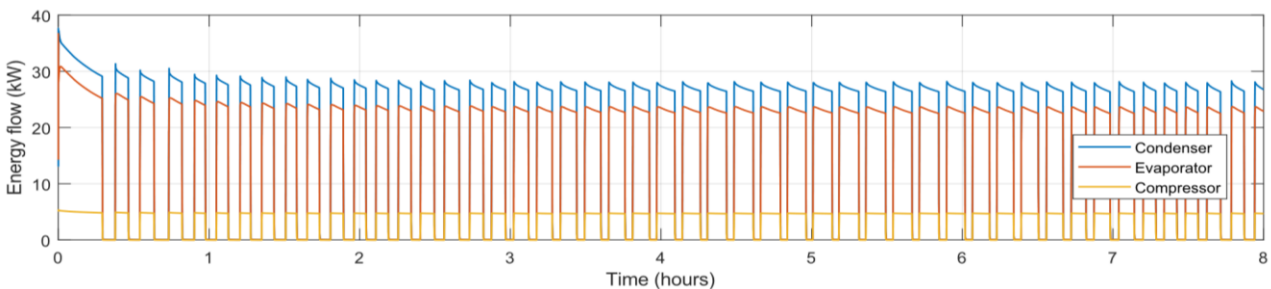

Fig. 15. Energy flows in the condenser, evaporator, and capacity consumed by the compressor

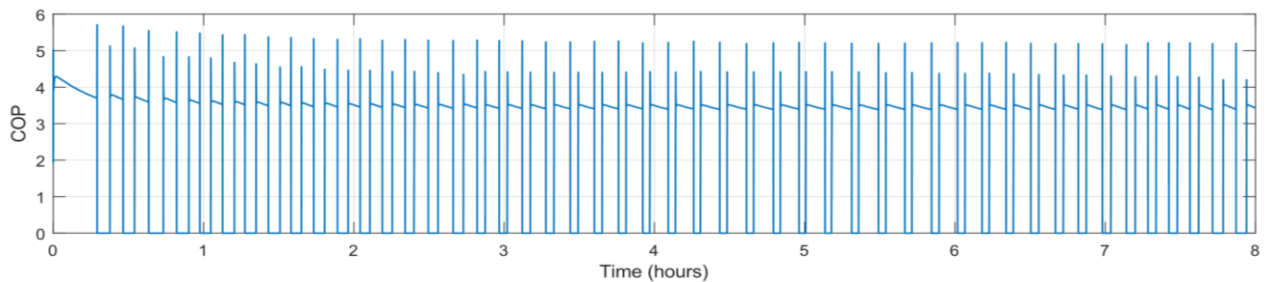

Fig. 16. Coefficient of efficiency

Fig. 17 shows graphs of the model operation inclusive of the specified indoor temperature maintenance and in the thermal accumulator.

The initial average indoor temperature is 30°C (the desired temperature is 22°C) and water temperature in the TA is 28°C (the desired temperature is 38 °C). During interval 1 (Fig. 17), i.e. from 0 h to 0.12 h, indoor temperature is more than the one specified at the thermostat. Water temperature in TA is lower than the predetermined value. Hence, within interval 1 (Fig. 11, mark 6), thermostats acquire air mass cooling as well as water heating in the TA. In this context, heat from the condenser (Fig. 13, mark 6) is not released to the environment using a fan, built into the external unit of the air conditioning system (Fig. 13, marks 1, and 2). A circulation pump is applied for its transferring to TA-condenser loop (Fig. 13, mark 4). At 0.12 h time moment, TA temperature achieves its specified value.

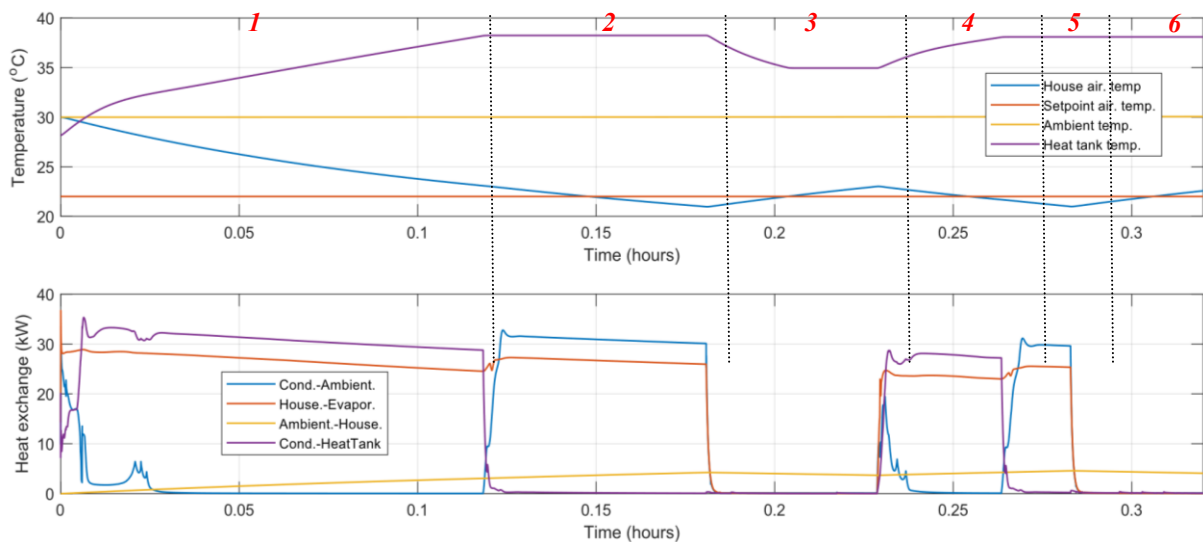

Fig. 17. Temperatures and heat exchange

The thermostat is turned off and switch to fan takes place (Fig. 13, mark 1) to remove heat from the condenser (i.e. *condenser-TA* heat exchange terminates and *condenser-environment* heat removal to the ambient medium starts). During interval 2, i.e. from 0.12 to 0.18 h, indoor air mass cooling is still in progress. The thermostat is turned off at 0.18 h time moment. Then, during 0.18-0.21 h interval, water consumption is simulated. At the time moment of 0.21, the thermostat is turned on to heat water (see Fig. 4.42). Nevertheless, relying upon logic, water heating is possible only at the moment when the conditioner turns on, i.e. during interval 4. 4, 5, and 6 intervals iterate processes within intervals 1, 2, and 3.

5. Conclusions

The paper has solved the topical scientific and applied problem as for analysis of energy, and technical and functional parameters of a heat supply system for residential building with the integrated means of automated control at the expense of synthesis of the computer-oriented as well as computer-integrated models of indoor heating and cooling using geothermal heat pump and thermal accumulator. The abovementioned makes it possible to improve energy efficiency of the building and optimize thermal energy use all the year round.

The developed models are the basis for the automated technology of computer-integrated control of heat-pump systems involving an energy efficiency criterion implementing the automated control of heating and cooling parameters. Versatility is to vary ergonomically thermal parameters of buildings and integrate heating and cooling systems of other types. Such an approach helps compare efficiency of the systems under the selected conditions and assess technical and functional parameters of one system under different operating conditions.

Future research will make it possible to expand and deepen scientific substantiation of software and technical solutions intended to improve energy efficiency of heat engineering objects and processes both for industries and households.

Literature

1. Directive (EU) 2023/1791 of the European Parliament and of the Council of 13 September 2023 on energy efficiency and amending Regulation (EU) 2023/955 [Електронний ресурс] // Official Journal of the European Union. – 2023. – Режим доступу до ресурсу: <https://eur-lex.europa.eu/eli/dir/2023/1791/oj>.
2. Van Cutsem O., Ho Dac D., Boudou P., Kayal M. Cooperative energy management of a community of smart-buildings: A Blockchain approach. *International Journal of Electrical Power & Energy Systems*. 2020. V. 117. <https://doi.org/10.1016/j.ijepes.2019.105643>.
3. Kolokotsa D., Diakaki C., Grigoroudis E., Stavrakakis G., Kalaitzakis K. Decision support methodologies on the energy efficiency and energy management in buildings. *Advances in Building Energy Research*. V. 3 (1). P. 121–146. <https://doi.org/10.3763/aber.2009.0305>.
4. Paolillo A., Carni D. L., Kermani M., Martirano L., Aiello A. An innovative Home and Building Automation design tool for Nanogrids Applications. *2019 IEEE International Conference on Environment and Electrical Engineering and 2019 IEEE Industrial and Commercial Power Systems Europe (EEEIC / I&CPS Europe)*, Genova, Italy. 2019. P. 1–5, <https://doi.org/10.1109/EEEIC.2019.8783878>.
5. A novel decentralized edge-enabled PReScriptivE and ProacTive framework for increased energy efficiency and well-being in residential buildings [Електронний ресурс] // European Commission – Режим доступу до ресурсу: <https://cordis.europa.eu/project/id/958284>.
6. Демченко В. Г. Дослідження непродуктивних втрат теплоти в теплових мережах та обґрунтування нового способу транспортування теплоносія [Електронний ресурс] / В. Г. Демченко // Інституту технічної теплофізики НАН України. – 2018. – Режим доступу до ресурсу: https://www.researchgate.net/publication/325260308_Doslidzenna_neproduktivnih_vtrat_teplosti_v_teplovih_merezah_ta_obgruntuvanna_novogo_sposobu_transportuvanna_teploносia.

7. Обсяг втрат теплової енергії у теплових мережах [Електронний ресурс] // Energy Map – Режим доступу до ресурсу: <https://map.ua-energy.org/uk/resources/67a172e1-f5f5-4605-9f69-4aeb7544d7b5/>.
8. Завгородня С.П. Пріоритетні енергоефективні заходи у сферах транспортування і постачання енергетичних ресурсів населенню [Електронний ресурс] / С. П. Завгородня // Національний інститут стратегічних досліджень – Режим доступу до ресурсу: <https://niss.gov.ua/sites/default/files/2021-12/az-transportuvannya-i-postachannya-energii.pdf>.
9. Демченко В. Г. Технології зберігання теплоти в системі центрального опалення / В. Г. Демченко. // *Проблеми екології та експлуатації об'єктів енергетики.* – 2021. – С. 1–4. https://www.researchgate.net/publication/352902341_Tehnologii_zberigannya_teplosti_v_sistemi_centralnogo_opalenna.
10. Ivanitskyi H.K., Konyk A.V., Stepaniuk A.R., Demchenko V.H. Simulation of heat exchange processes in the “thermal core” filled with heat accumulation material. *Energy Technologies & Resource Saving*. 2023. V. 76. P. 52–70. <https://doi.org/10.33070/etars.3.2023.05>.
11. Олішевський І.Г., Олішевський Г.С. Автоматизована методика розрахунку параметрів для нетрадиційних технологій опалення та кондиціонування будівель. *Електротехніка та електроенергетика*. Запоріжжя, 2021. № 3. С. 40–47. <https://doi.org/10.15588/1607-6761-2021-3-4>.
12. Система опалення будівлі: пат. на винахід № 123931 Україна: МПК (2021.01), F24D 3/10 (2006.01), F24D 3/18 (2006.01), F24D 15/00, F24D 4/04 (2006.01), F24S 90/00, F25B 29/00. № а 2019 11504; заявл. 28.11.2019; опубл. 23.06.2021. Бюл. № 25. 8 с. Винахідники: Олішевський І.Г., Олішевський Г.С., Гусев О.Ю.
13. Олішевський І.Г., Гусев О.Ю. Розробка інформаційно-виміральної системи для керування роботою комплексної системи опалення та кондиціонування. *Молодь: наука та інновації: Матеріали Х Міжн. наук.-техн. конф. студ. асп. та мол. вчених. м. Дніпро, 23–25 лист. 2022 р.* Дніпро: НТУ «ДП», 2022. С. 369–370. URL: <https://rmv.nmu.org.ua/ua/arkhiv-zbirok-konferentsiy/molod-nauka-ta-innovatsii-2022/molod-2022.pdf>.
14. Try MATLAB, Simulink, and More [Електронний ресурс] // The MathWorks, Inc. – Режим доступу до ресурсу: <https://www.mathworks.com/campaigns/products/trials.html>.
15. System-Level Condenser Evaporator (2P-MA) [Електронний ресурс] // The MathWorks, Inc., Simscape Fluids – Режим доступу до ресурсу: https://www.mathworks.com/help/hydro/ref/systemlevelcondenserevaporator2pma.html?s_tid=doc_ta.

References

1. Directive (EU) 2023/1791 of the European Parliament and of the Council of 13 September 2023 on energy efficiency and amending Regulation (EU) 2023/955 [E resource] // Official Journal of the European Union. – 2023. – Access mode: <https://eur-lex.europa.eu/eli/dir/2023/1791/oj>.
2. Van Cutsem O., Ho Dac D., Boudou P., Kayal M. Cooperative energy management of a community of smart-buildings: A Blockchain approach. *International Journal of Electrical Power & Energy Systems*. 2020. V. 117. <https://doi.org/10.1016/j.ijepes.2019.105643>.
3. Kolokotsa D., Diakaki C., Grigoroudis E., Stavrakakis G., Kalaitzakis K. Decision support methodologies on the energy efficiency and energy management in buildings. *Advances in Building Energy Research*. V. 3 (1). P. 121–146. <https://doi.org/10.3763/aber.2009.0305>.
4. Paolillo A., Cami D. L., Kermani M., Martirano L., Aiello A. An innovative Home and Building Automation design tool for Nanogrids Applications. *2019 IEEE International Conference on Environment and Electrical Engineering and 2019 IEEE Industrial and Commercial Power Systems Europe (EEEIC / I&CPS Europe)*, Genova, Italy. 2019. P. 1–5. <https://doi.org/10.1109/EEEIC.2019.8783878>.
5. A novel decentralized edge-enabled PREsCripTivE and ProAcTive framework for increased energy efficiency and well-being in residential buildings [E resource] // European Commission – Access mode: <https://cordis.europa.eu/project/id/958284>.
6. Demchenko, V.H. Analysis of nonproductive heat losses in thermal networks, and substantiation of a new procedure for thermal medium transportation [E resource] / V. H. Demchenko // Institute of Engineering Thermophysics of the NAS of Ukraine. – 2018. – Access mode: https://www.researchgate.net/publication/325260308_Doslidzenna_neproduktivnih_vtrat_teplosti_v_teplovih_merezah_ta_obgruntuvanna_novogo_sposobu_transportuvanna_teplosnia.
7. The volume of thermal energy losses in heat networks [E resource] // Energy Map – Access mode: <https://map.ua-energy.org/uk/resources/67a172e1-f5f5-4605-9f69-4aeb7544d7b5/>.
8. Zavorodnia, S.P. Priority energy-efficient measures in the field of energy resource transportation and delivery to people [E resource] / S. P. Zavorodnia // National Institute for Strategic Studies – Access mode: <https://niss.gov.ua/sites/default/files/2021-12/az-transportuvannya-i-postachannya-energii.pdf>.
9. Demchenko, V.H. The technologies for heat storage within the central heating system / V.H. Demchenko. // *Problems of ecology and operation of energy facilities.* – 2021. – Pp. 1–4. https://www.researchgate.net/publication/352902341_Tehnologii_zberigannya_teplosti_v_sistemi_centralnogo_opalenna.
10. Ivanitskyi H.K., Konyk A.V., Stepaniuk A.R., Demchenko V.H. Simulation of heat exchange processes in the “thermal core” filled with heat accumulation material. *Energy Technologies & Resource Saving*. 2023. V. 76. P. 52–70. <https://doi.org/10.33070/etars.3.2023.05>.
11. Olishkevskiy, I. H., & Olishkevskiy, H.S. Automated methods to calculate parameters for nontraditional indoor heating and cooling techniques. *Electrical technology and electrical energy industry. Zaporizhzhia*, 2021. #3. Pp. 40–47. <https://doi.org/10.15588/1607-6761-2021-3-4>.
12. Indoor heating system: patent for invention # 123931 Ukraine: МПК (2021.01), F24D 3/10 (2006.01), F24D 3/18 (2006.01), F24D 15/00, F24D 4/04 (2006.01), F24S 90/00, F25B 29/00. # а 2019 11504; application of 28.11.2019; published 23.06.2021. Bulletin # 25. 8 pages. Inventors: Olishkevskiy, I. H., Olishkevskiy, H.S., & Husiev, O.Yu.
13. Olishkevskiy, I. H., & Husiev, O.Yu. Development of information and measurement system to control complex heating and conditioning system. *Molod: science and innovations: Proceedings of 10th International Scientific and Technical Conference for Students, Postgraduates, and Young Scientists, Dnipro, November 23–25, 2022.* Dnipro: Dnipro University of Technology, 2022. Pp. 369–370. URL: <https://rmv.nmu.org.ua/ua/arkhiv-zbirok-konferentsiy/molod-nauka-ta-innovatsii-2022/molod-2022.pdf>.
14. Try MATLAB, Simulink, and More [E resource] // The MathWorks, Inc. – Access mode: <https://www.mathworks.com/campaigns/products/trials.html>.
15. System-Level Condenser Evaporator (2P-MA) [E resource] // The MathWorks, Inc., Simscape Fluids – Access mode: https://www.mathworks.com/help/hydro/ref/systemlevelcondenserevaporator2pma.html?s_tid=doc_ta.